

# TABLES

**You should have...**

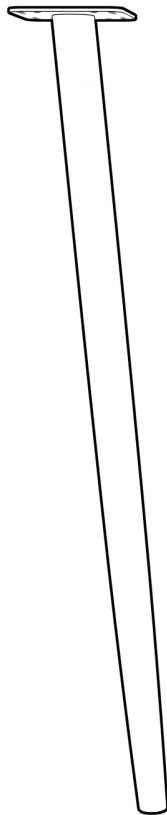

**Table Top**



**4x Legs**

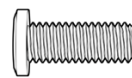

**16x Screws**

**\*You will also need a phillips head screwdriver, not included**

---

Note: Please retain all boxes until you are certain that your product isn't damaged and that you do not wish to return it. Disposal of boxes may prevent/delay our ability to resolve your request.

---

## Step 1: Attach the First Leg

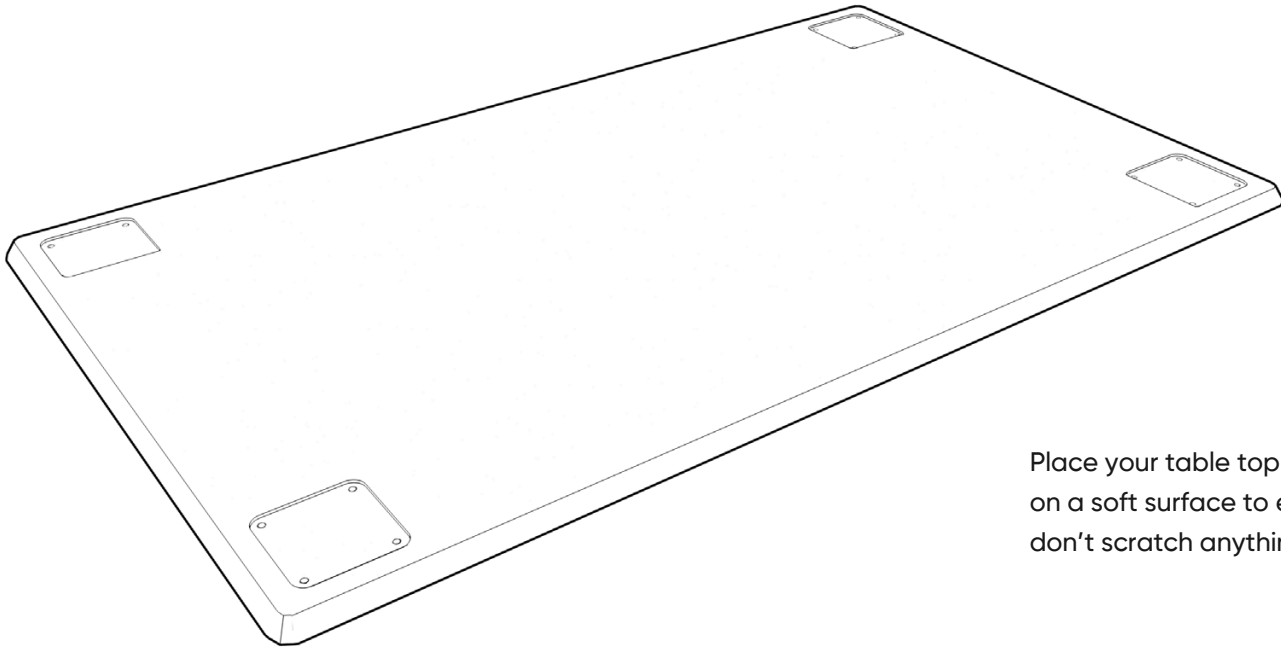

Place your table top face down on a soft surface to ensure you don't scratch anything.

Grab a leg and 4 screws along with a phillips head screwdriver (not included). Flip your leg upside down so that the leg plate is facing the bottom of your table. Rotate the leg plate until the foot of the leg is angled away from the center of your table and place it into one of the inset pockets.

While holding your leg in place, insert the screws through each corner of the leg plate and hand tighten. With your screwdriver tighten evenly in a criss-cross pattern. Do not overtighten.

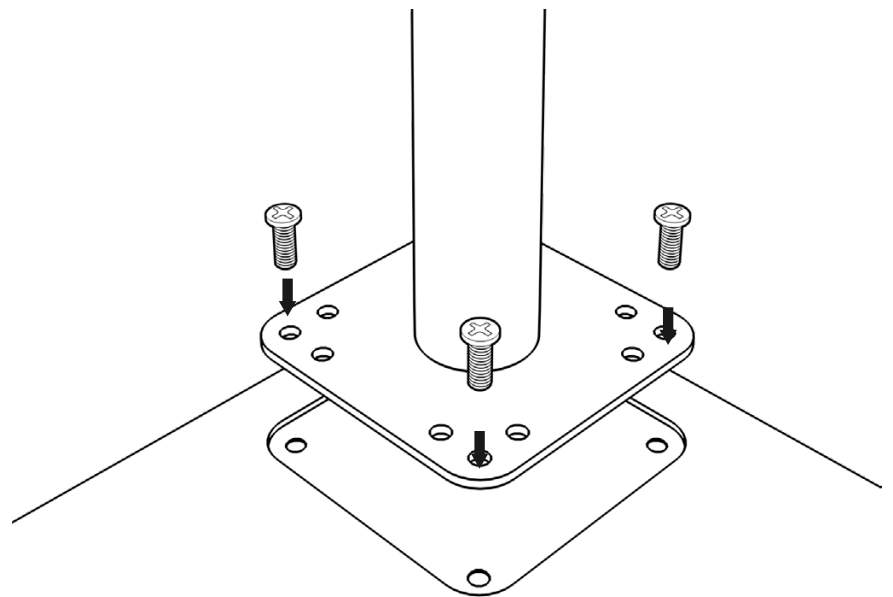

## Step 2: Attach the Other Legs

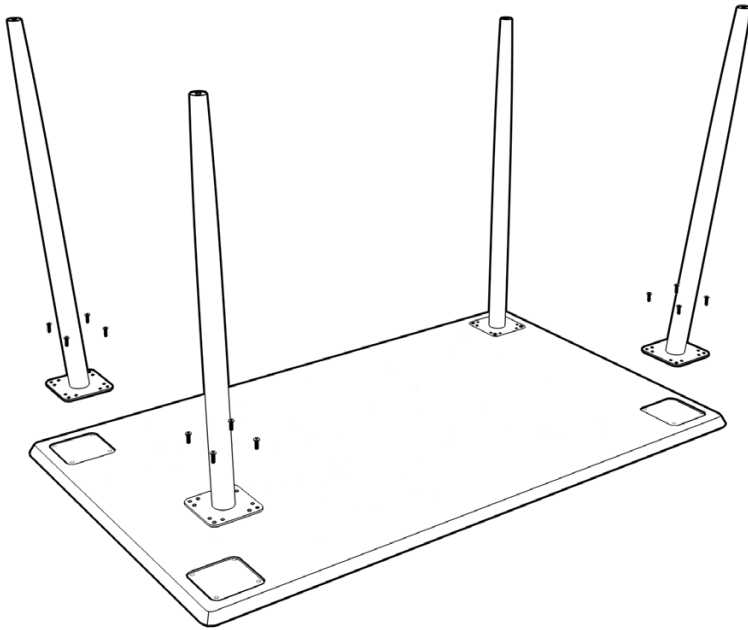

Repeat the previous step with the remaining legs.

Note: Our legs have an angle - make sure all 4 legs are angled out when you view them from the top down.

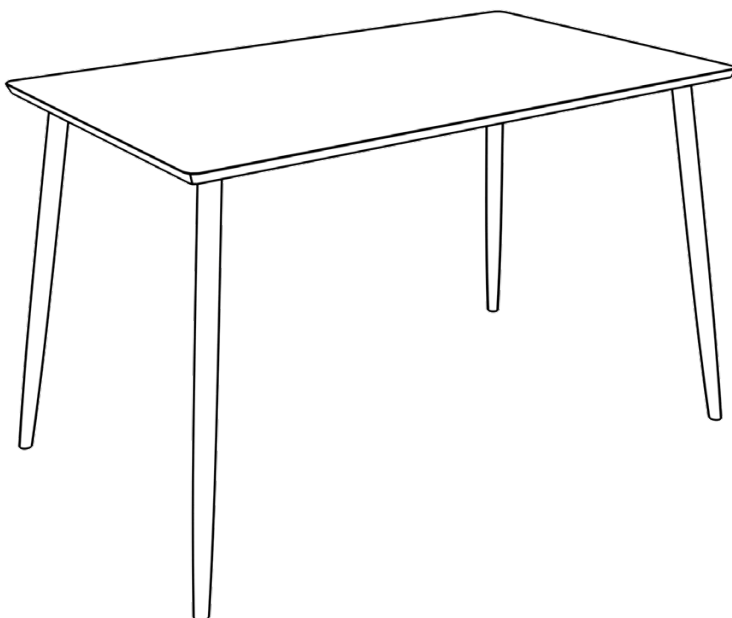
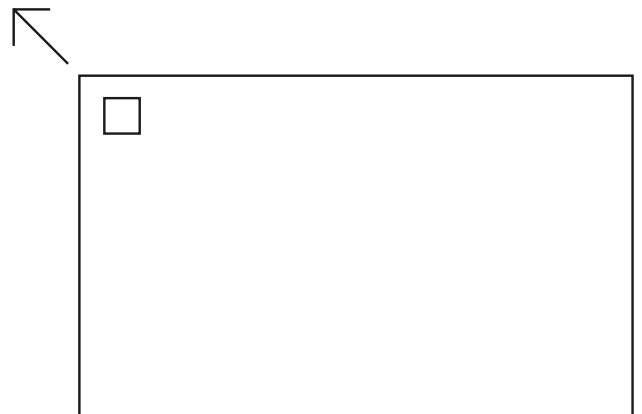

Flip the table over and you're done!